

# SVK-22

Sluckey 12/02/2022

Based on Fender Vibro King

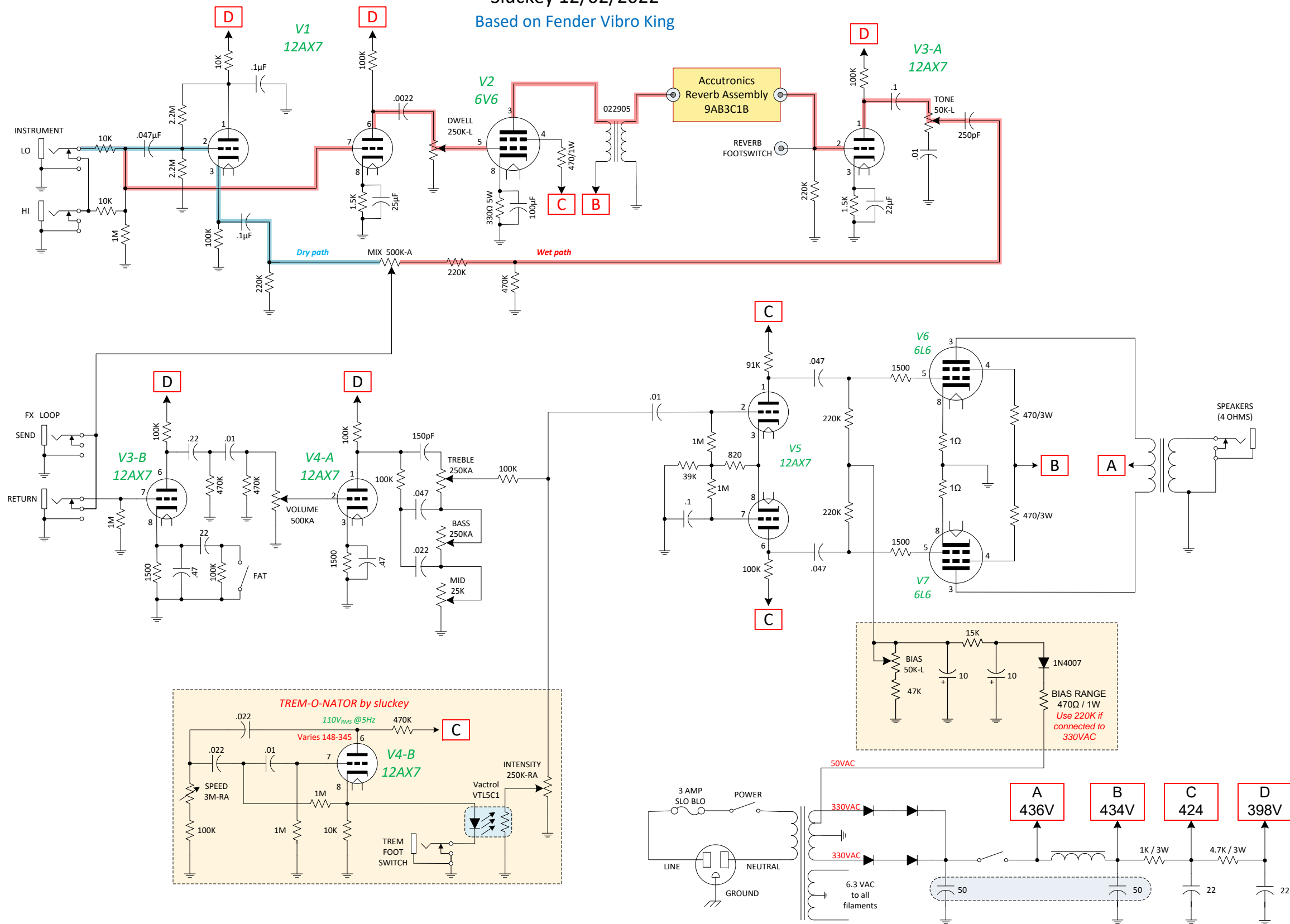

# SVK-22

Sluckey 12/02/2022

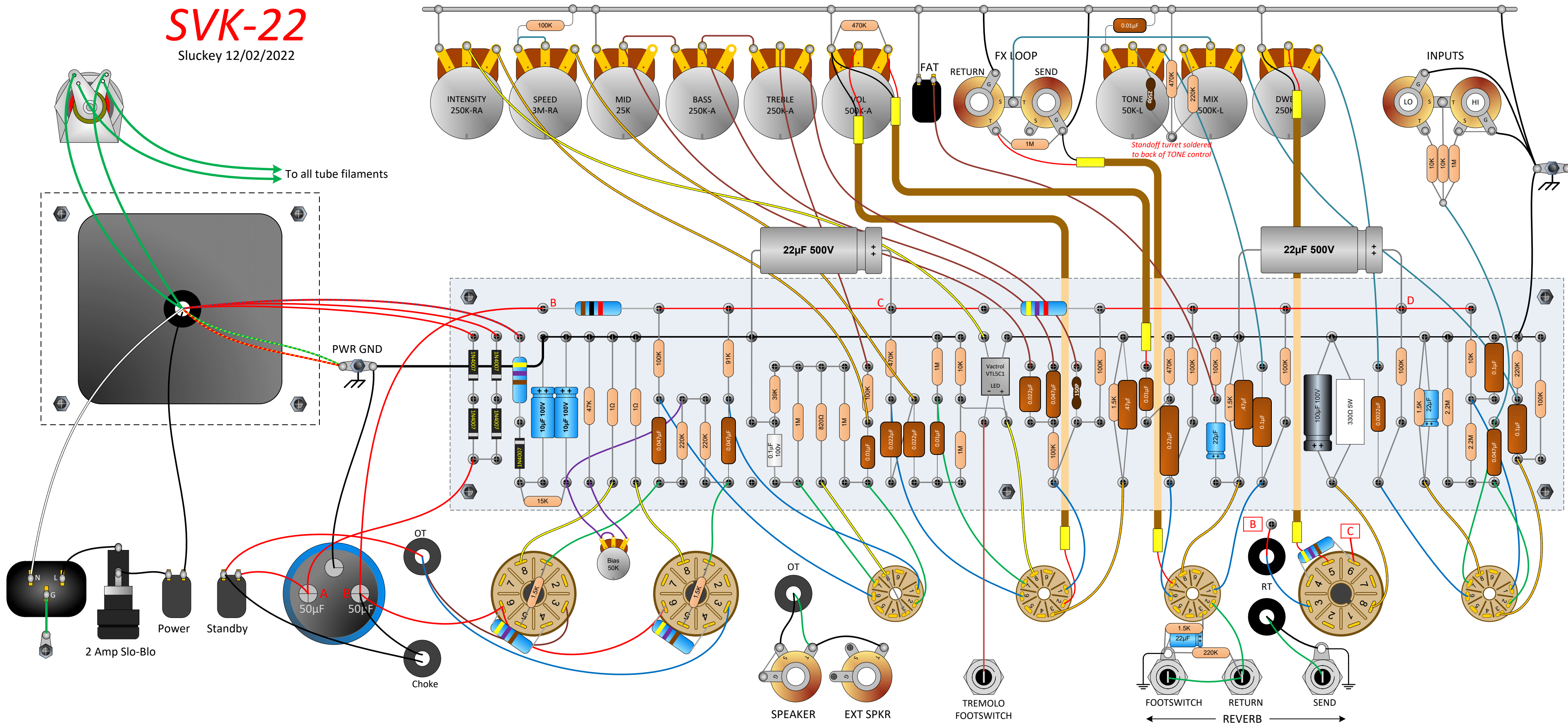

To all tube filaments

Standoff turret soldered to back of TONE control

PWR GND





SPEAKER EXT SPKR

TREMOLO FOOTSWITCH

FOOTSWITCH RETURN REVERB SEND

# DRILL GUIDE

## INSTRUCTIONS FOR PRINTING DRILL GUIDE

-  Turret --- drill size is 3/32"
-  Standoff – drill size to fit
-  Hole for wire pass thru – drill size to fit
-  Dashed lines are underboard jumpers. It's OK to put on top side of board.

Board size is 3 1/8" X 15". Print this drill guide FULL SIZE on 11" x 17" paper. Use one template as a drill guide. The other template will be used for installing jumpers. Measure the board length of the printout to verify it is 15". Attach to blank board using double sided carpet tape or spray adhesive. Use a center punch to put a mark at the cross hairs of each turret, standoff, and hole. Use a 3/32" drill bit to drill all holes. Then enlarge holes as needed for screws and wire pass thru.

