



**GUITAR, AMPLIFIER, CASE COMBINATION**

**HOW TO ORDER PARTS:**

**WHERE TO PLACE ORDER:**

Replacement parts may be ordered through any Sears, Roebuck and Co. U.S.A., or in Canada, Simpsons-Sears Limited Retail or Mail Order Store. Prices available upon application.

**ORDER MUST STATE:**

1. The Part Number
2. The Part Description
3. The Chassis Number
4. The Model Number

**USED IN MODELS**

**1449**

**1457**

**LOCATION OF CHASSIS AND MODEL NUMBERS:**

The chassis number will be found on a metal plate attached to the chassis.  
The model number will be found on the control panel.

**NOTES:**

1. VALUES OF CAPACITORS IN MFD. UNLESS OTHERWISE NOTED.
2. ALL RESISTORS ARE 1/2 WATT UNLESS OTHERWISE NOTED.
3. VOLTAGES MEASURED FROM POINTS INDICATED TO CHASSIS WITH 20,000 OHM/VOLT METER.

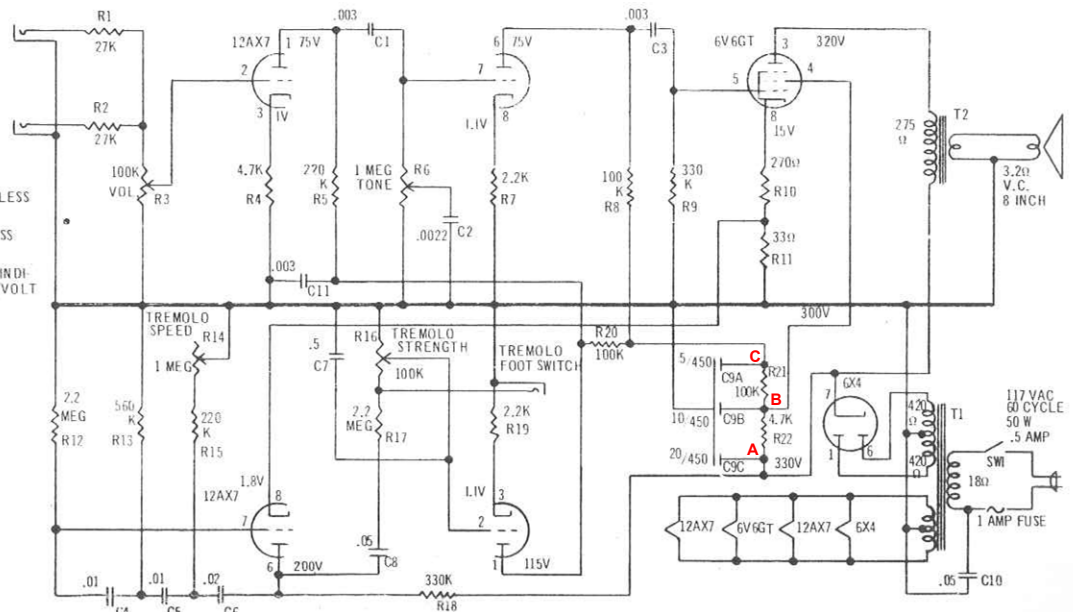

**SCHEMATIC DIAGRAM OF SILVERTONE CHASSIS 185.11090**

CHASSIS PARTS						CABINET PARTS	
Schematic Location	Part No.	Description	Schematic Location	Part No.	Description	Part No.	Description
<b>CAPACITORS</b>			<b>RESISTORS</b>			1449C	Case for 1449
C1, C3, C11	20-0036	.003 mfd., 600 v.	(All resistors 1/2 watt unless otherwise noted)			1457C	Case for 1457
C2	20-220	.0022 mfd., 600 v.	R1, R2	18-27302	27K ohm, 20%	7835	Handle with hardware
C4, C5	20-016	.01 mfd., 600 v.	R3, R16	22-10412	100K ohm control, linear	53N	Hinge
C6	20-026	.02 mfd., 600 v.	R4, R22	18-47202	4.7K ohm, 20%	3011N	Catch
C7	20-502	.5 mfd., 200 v.	R5, R15	18-22402	220K ohm, 20%	273	Lid support
C8, C10	20-056	.05 mfd., 600 v.	R6	22-10512	1 megohm control, audio taper	8M32	Speaker, 8 inch, 3.2 ohm V.C.
C9A-C9B-C9C	25-51020	Electrolytic, 5-10-20 mfd., 450 v.	R7, R19	18-22202	2.2K ohm, 20%	1457M-V2	Owner's Manual
<b>MISCELLANEOUS PARTS</b>			R8, R20, R21	18-10402	100K ohm, 20%		
T1	P-7	Power Transformer	R9, R18	18-33402	330K ohm, 20%		
T2	091	Output Transformer	R10	18-27151	270 ohm, 10%, 5watt		
SW1	2019	Toggle Switch SPST	R11	18-33002	33 ohm, 20%		
	83130BL	Control Knob, Black	R12, R17	18-22502	2.2 megohm, 20%		
	FS49	Single Foot Switch	R13	18-56402	560K ohm, 20%		
			R14	22-10513	1 megohm control, linear		

**SEARS' TECHNICIAN ONLY**

Refer to the Div. 57 Authorized Price List 185.00 for current selling prices, availability and ordering information.

Remove and destroy the corresponding page from the Div. 57 Standard Nomenclature Radio Technical Manual and file this revised page in its place.

SF57-

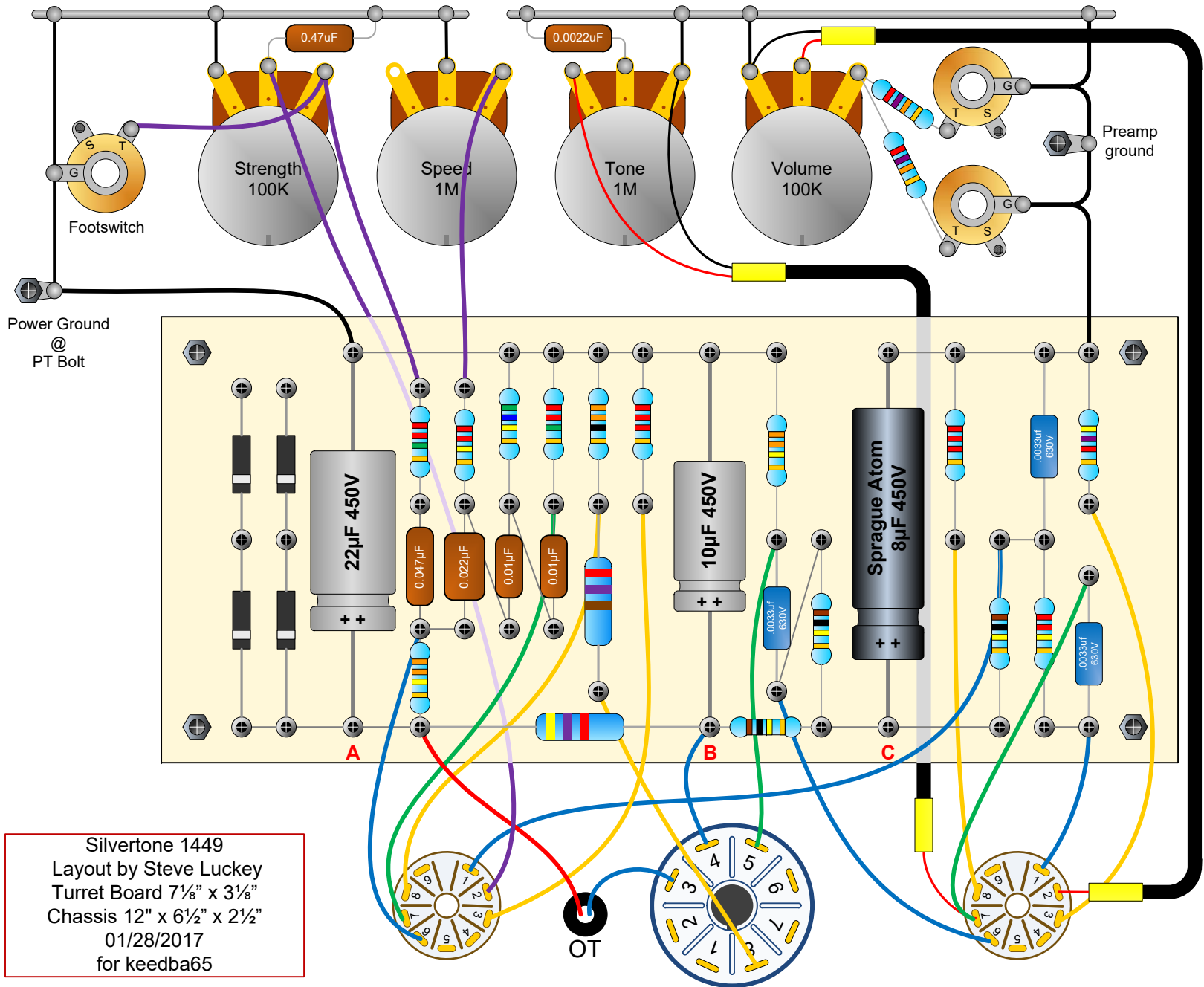

Silvertone 1449  
 Layout by Steve Luckey  
 Turret Board 7 1/8" x 3 1/8"  
 Chassis 12" x 6 1/2" x 2 1/2"  
 01/28/2017  
 for keedba65

# DRILL/JUMPER GUIDE

## INSTRUCTIONS FOR PRINTING DRILL GUIDE

⊕ Turret --- drill size is 3/32"

⊕ Standoff – drill size to fit

⊕ Hole for wire pass thru – drill size to fit

----- Dashed lines are underboard jumpers

Board size is 3-1/8" X 7-1/8". Print 2 copies of this drill guide FULL SIZE on letter sized paper. Use one template as a drill guide. The other template will be used for installing jumpers. Measure the board length of the printout to verify it is 7-1/8". Attach to blank board using double sided carpet tape or spray adhesive. Use a center punch to put a mark at the cross hairs of each turret, standoff, and hole. Use a 3/32" drill bit to drill all holes. Then enlarge holes as needed for standoff screws and wire pass thru. Remove paper template from board and clean board thoroughly using mineral spirits and denatured alcohol. Load turrets.

